

INSTRUCTIONS

REPAIR PARTS LIST AND WARRANTY INFORMATION

WPO12E, WPO12N MPO12E, MPO12N POLY, ELECTRIC DRINKERS

READ ALL DIRECTIONS CAREFULLY BEFORE BEGINNING INSTALLATION



WARNING



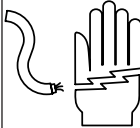

1. **INSTALLATION MUST BE MADE AND MAINTAINED IN STRICT ACCORDANCE WITH NATIONAL/LOCAL PLUMBING AND NATIONAL/LOCAL ELECTRICAL CODES (CSA IN CANADA). INSTALLATION MUST BE MADE BY A QUALIFIED ELECTRICIAN. THE APPLICABLE PROVISIONS OF THE ABOVE MENTIONED CODES TAKE PRECEDENT. IMPROPER ELECTRICAL INSTALLATION AND MAINTENANCE MAY RESULT IN SERIOUS INJURY OR DEATH FOR PERSONNEL OR LIVESTOCK.**
2. **EACH ELECTRICAL UNIT MUST BE WIRED THROUGH A FUSED SWITCH BOX AND FUSED ACCORDING TO AMPS REQUIRED FOR EACH SPECIFIED ELECTRICAL UNIT. SEE EXHIBIT A. CANADIAN ELECTRICAL CODE--PART 1 REQUIRES LIVESTOCK WATERERS INSTALLED IN FEEDLOTS IN OPEN FEEDING AREAS TO BE GROUNDED BY A SEPARATE STRANDED COPPER GROUNDING CONDUCTOR OF AT LEAST NO. 6 AWG TERMINATING AT A POINT WHERE THE BRANCH CIRCUIT RECEIVES ITS SUPPLY.**
3. **THIS UNIT MUST BE GROUNDED TO A COPPER GROUND ROD 5/8" (1.6CM) DIAMETER BURIED AT LEAST 8 FEET (2.5 METERS) IN UNDISTURBED SOIL. SEE EXHIBIT A.**
4. **DO NOT USE SUPPLEMENTAL HEAT SUCH AS A SPACE HEATER.**

REPAIR PARTS LIST - See Exhibit I on PAGE 6 for location of parts

Ref No.	Part Num-ber	Description	Qty.	Ref No.	Part Num-ber	Description	Qty.
1	WPO1710A	2 Hole Drinker Lid Assy, Pride of the Farm, Blue	1	9	VP115	Adjusting Screw, 1/4-20, Plastic	2
1	MPO1710A	2 Hole Drinker Lid Assy, Brower, Red	1	10	VP223	Valve Assembly, 1/8" Orifice	1
2	WPO1211	2 Hole Drinker Base, Blue	1	11	OF627	Washer, 1 x 10 GA, Zinc	1
2	MPO1211	2 Hole Drinker Base, Red	1	12	OP120	#11 Rubber Stopper	1
3	WPO1213A	Door Assembly, Blue	1	13	OP210	1 1/2 NPT Plug, Plastic	1
3	MPO1213A	Door Assembly, Red	1	14	WPO1714	Base Seal, 84"	1
4	OP344	3 SCH 40 PVC x 12 1/2" Riser Tube	1	15	WPO1220	Valve Supply Line Assy	1
	WPO1217	Valve/Supply Line Assembly Hardware Bag includes Ref. Nos. 5 through 15 and the instruction sheet	1		WPO1216	Heater Assembly Hardware Bag Includes Ref. Nos. 16 through 18	1
5	OP296	3 Male Adapter, Hub MIPT	1	16	OP284P	C250 Utility De-Icer with Plug	1
6	OP297	O-Ring, 3-1/2 x 3/16	1	17	OP93	11 Tywrap	2
7	VM117	Float, Poly	1	18	WPO256	Heat Tape (Not Shown)	1
8	VA4	Valve Arm, 4", Poly	1	19	WT208	Foam Pipe Insulation, 36"	1
					ISHWPO12	Instruction Sheet	1

MODEL NUMBER

The MODEL NUMBERS are: WPO12E, WPO12N, MPO12E, MPO12N Drinkers

WHEN ORDERING PARTS

- (1) Show MODEL NUMBER and NAME: Example - WPO12E Poly Drinker
- (2) Show PART NUMBER and FULL DESCRIPTION of part: Example - OP210 1 1/2" NPT Plug, Plastic

HOW TO ORDER PARTS

Repair parts may be ordered from your dealer.



EXHIBIT A

**NOTE: Check local codes.
Some jurisdictions require 2
grounds & rods.**

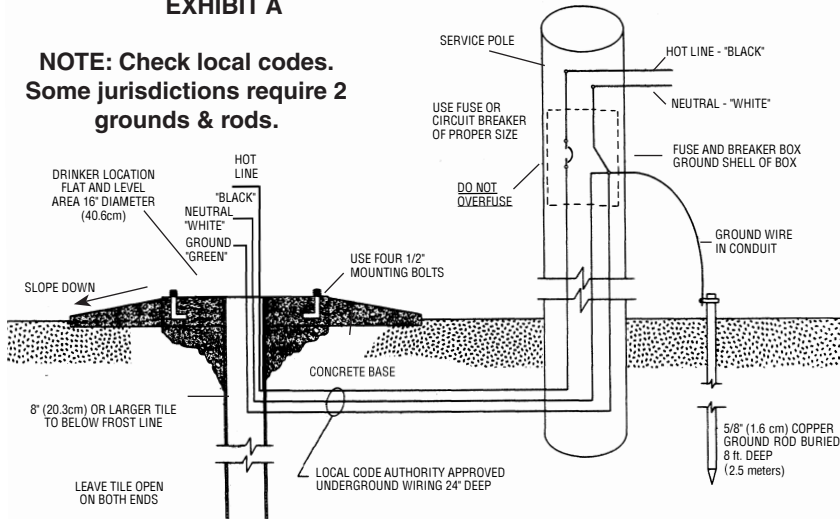

The following is intended to be used as a general guide for wiring electrically heated waterers. Paragraph 5, 6, and 7 are taken from ASAE Engineering Practice: ASAE EP 342.3. Safety for Electrically Heated Livestock Waterers, October 2015. Installation can only be completed by a qualified electrician.

5. Electrical Service

- 5.1 Service conductors should conform to the following:
 - 5.1.1 Conductors shall have sufficient ampacity for the load to be served.
 - 5.1.2 Overhead conductors shall have mechanical strength for the distance spanned. The conductors shall not be smaller than NO. 8 American wire gage, AWG, copper.
 - 5.1.3 Buried connectors shall be of type USE (or UF when protected as a feeder or

branch circuit) and shall be buried at least 610mm (24 in.) below the ground surface (or according to state/load codes). Wet rated conductors in non-metallic conduit are also recommended for providing service.

5.2 Waterer installed near or in a building may be served by a dedicated 15A GFI from the service equipment of the building.

6. Supply Circuits

- 6.1 Waterers installed within or near a building and shall be served by a dedicated 15A GFI from the service equipment of the building and shall be connected as in Exhibit B.
 - 6.1.1 The equipment grounding conductor shall originate at the service equipment of the building.
 - 6.1.2 The equipment grounding conductor shall be connected to the equipment grounding terminal of the waterer and bonded to any intermediate enclosure or device that requires grounding. The equipment grounding conductor shall be isolated from the grounded (neutral) conductor at every point beyond service equipment.
- 6.2 An individual waterer installed in a lot and served by separate service equipment shall be connected as in Exhibit C.
 - 6.2.1 Overhead conductors shall be firmly attached to support points and conform to 5.1.1 and 5.1.2. Buried conductors shall conform to 5.1.3.
 - 6.2.2 The incoming grounded conductor shall be bonded to the service equipment enclosure and to a grounding electrode conductor at the grounding bar in the service equipment. The grounding electrode conductor shall extend to a grounding electrode (a ground rod or other effective electrode).
 - 6.2.3 An equipment grounding conductor shall originate at the service equipment and shall be installed with the circuit conductors to the waterer.
 - 6.2.4 The equipment grounding conductor shall be installed as described in 6.1.2.

7. Multiple Installations

- 7.1 When more than one waterer is to be served from a central service, the service equipment should be located near the load center.
- 7.2 Each waterer shall be connected as specified in 6.2.

NOTE: THE USE OF THE RISER PIPE AS A GROUNDING MEANS IS NOT RECOMMENDED

There shall be only **one** ground fault interrupter in the electrical delivery to the waterer.

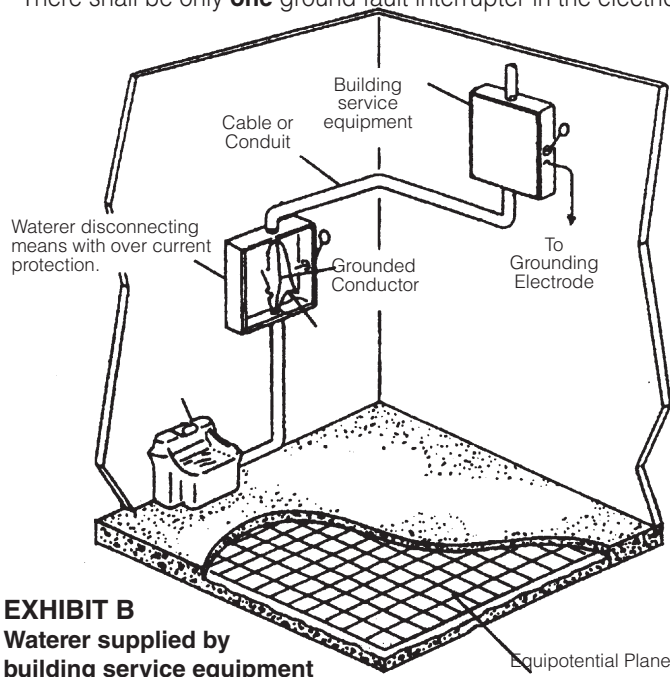

**EXHIBIT B
Waterer supplied by
building service equipment**

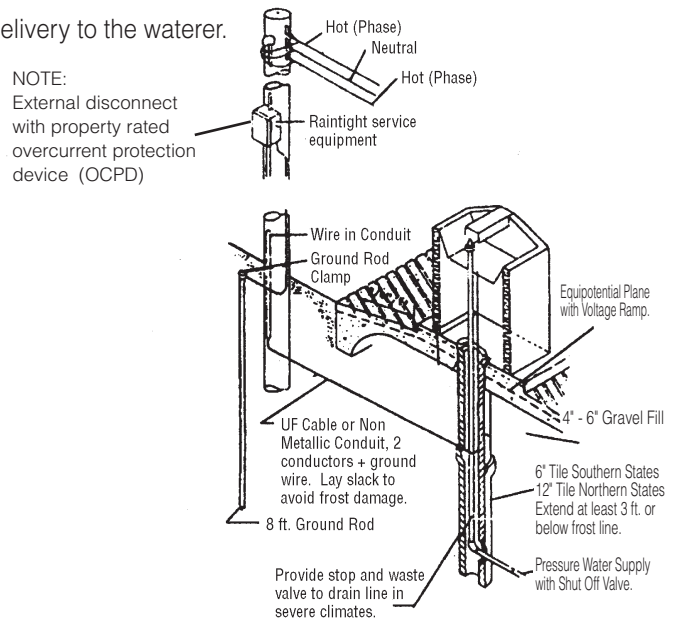

**EXHIBIT C
Waterer supplied by its own service equipment**

STEP 1: Get your qualified electrician involved in the planning of your installation. Review Exhibits A, B, and C on page 2. Also, there is a suggested electrical outlet box addition shown on the top of page 8.

STEP 2: RISER TILE

The ideal size of riser depends on the installation, source of water and geography. If you are replacing an existing waterer and have had no supply line freezing problems and have been using no supplemental heat on your supply line, you can probably use your existing tile as long as it is large enough to accommodate the insulated sleeve. (Ref No. 19). For best protection, we recommend that a new riser tile of at least 8 inches (20.3 cm) diameter be installed. **INSTALLATION MUST BE MADE WITHOUT THE SUPPLY LINE TOUCHING THE RISER TILE AND THERE MUST BE NO DEBRIS OR DIRT IN THE RISER TILE. DO NOT STUFF YOUR RISER TILE WITH INSULATION AS IT CAN BECOME WATER LOGGED RESULTING IN FROST PENETRATION.** If the installation is north of Interstate 90 or if frost heaving is a problem in your area, use a flexible supply line, such as 3/4 inch (1.9 cm) braided vinyl tubing available at most plumbing supply outlets. If your water supply line is flexible and you are concerned that the flex may cause it to touch the riser tile, use a deep well submersible cable guard (a nylon plate that slips over the supply line and keeps it centered). Ask for a deep well submersible cable guard at your local plumbing supply outlet. **BE SURE TO USE THE FOAM PIPE INSULATION PROVIDED AROUND YOUR SUPPLY LINE.** Make sure the insulation does not touch the riser tile as well.

Where water is 54°F (12°C) or higher, you will probably not need to use a tile larger than 8 inches (20.3 cm) diameter. If entering water is 50°F (10°C) or colder, we recommend a tile of about 12 inches (30.5 cm) diameter. If incoming water has a temperature of the lower 40's (about 4°C), use a 14 inch (35.6 cm) tile.

STEP 3: MOUNTING PAD

Concrete pad should be about 4 inches (10.2 cm) thick. Surface area where drinker sits should be smooth and level to provide a good seal. From the edge of the drinker, pad should slope about one-quarter inch per foot (about 1 cm per 48 cm). The size of the pad is left to the user's discretion but we suggest you pour a pad large enough for livestock to stand on while drinking (about 19 inches (48 cm) beyond the edge of unit on all four sides). A rough broom finish provides better livestock footing. NOTE: The area where drinker sits should be smooth. A styrofoam barrier should be provided around the riser tile. Supply line should be at least 3/4 inch (1.9 cm) diameter. However, line should be sized to account for any pressure drop relating to distance. Water lines over 50 feet (15 meters) should be one inch (2.54 cm) or larger. Use of undersized supply line may cause loss of recovery capability.

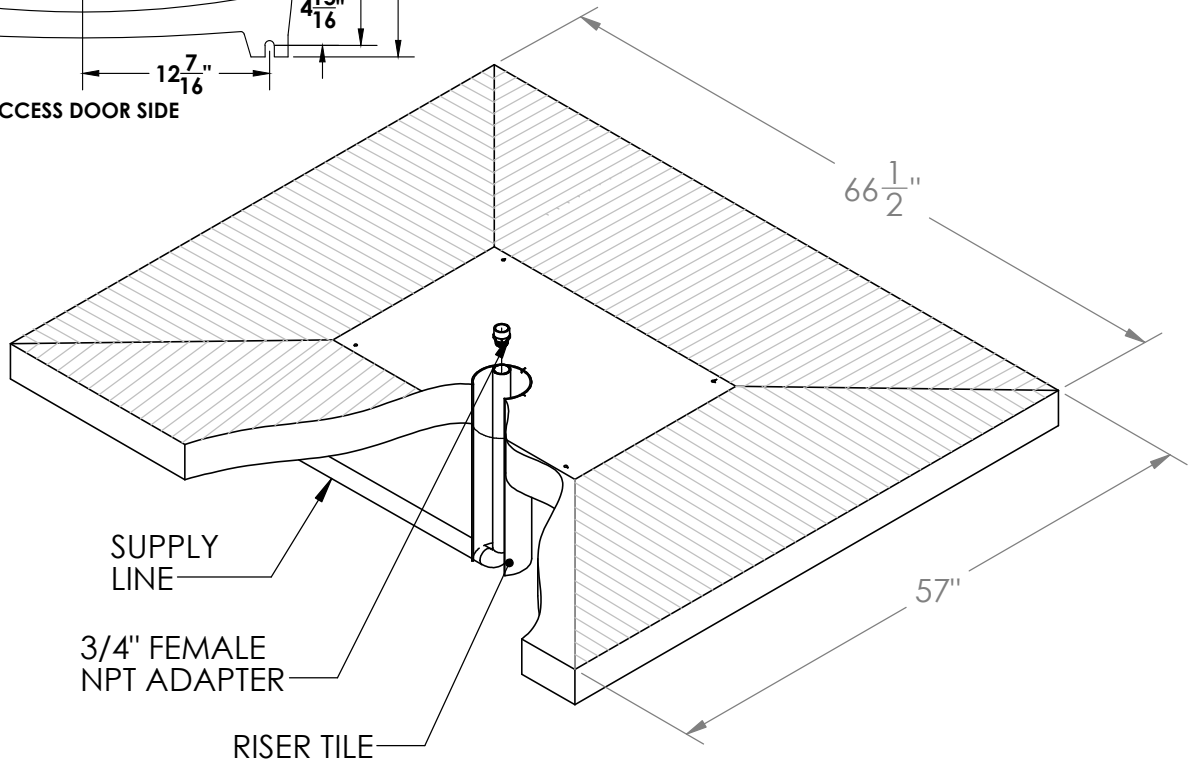
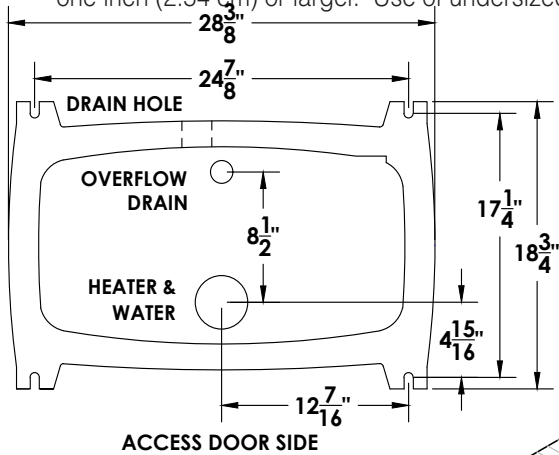

STEP 4: INSTALL RISER ASSEMBLY

1. Install **Ref No. 6 O-Ring** onto the threads of Ref No. 5 hub. Use teflon tape or thread compound on the threads of the hub. Install the hub into the three inch hole in the floor of the drinker base. Make sure the hub is tight.
2. Glue Ref No. 4 riser tube into the hub **MAKING SURE THE HOLE IN THE TOP OF Ref No. 4 Riser Tube IS TURNED INWARD SO THAT THE VALVE AND FLOAT ARE CENTERED IN THE VALVE COVER.**

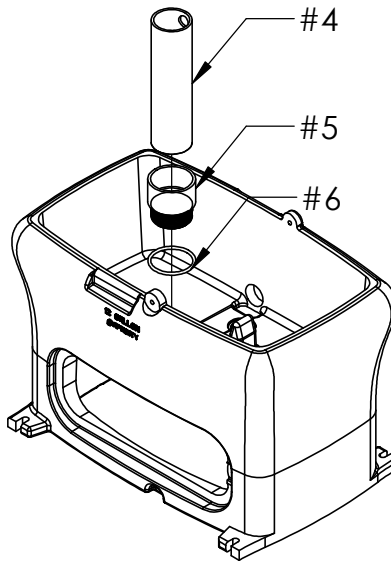

STEP 5: INSTALL HEATER

1. Place the "donut" hole of the heater onto the "bump" in the floor of the base. The heater has three feet, ½ inch long. Place the heater so that the feet touch the floor.
2. Thread the cord through the riser assembly so that the plug is in the cavity below the floor.
3. Take the slack out of the cord so that 1. there can be no interference with the operation of the float and 2. animals cannot get access to the cord. Zip tie the cord behind the riser assembly using **Ref No. 17 Tywrap**.

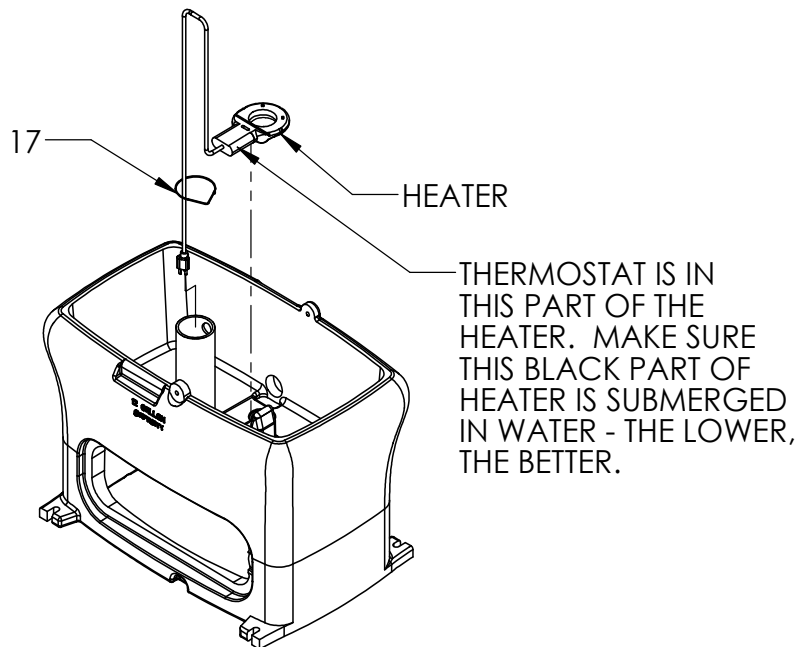

STEP 6: MOUNT DRINKER TO PAD.

1. Slide **Ref. No. 19 Foam Pipe Insulation** over your incoming water supply line making it at least even with the top of the riser tile or it can extend an inch or two(2-5 cm) up into the cavity of the drinker. Hold foam insulation in place at the top with **Ref. No. 17 Tywrap**.
2. Stick **Ref. No. 18 Base Seal** to base bottom inside the anchor slots. You can also use a plumber's putty to seal the base.
3. Set the base of the drinker over your riser tile coming out of the ground and position base so that you have a convenient hookup to both your electrical and water supply lines.
4. Connect your incoming water supply line to **Ref. No.15 Supply Line Assembly**. Use Teflon tape or a thread compound.
5. Make your electrical connection. In cold weather season, you should also plug in the furnished heat tape and wrap it around your water supply line underneath the drinker trough.
6. When you are comfortable with the positioning of your drinker relative to the water and electrical supply hookups, lag drinker to pad. **USE AN ANTISEIZE COMPOUND** (Permatex brand or equivalent) on the lag bolt threads and nuts.

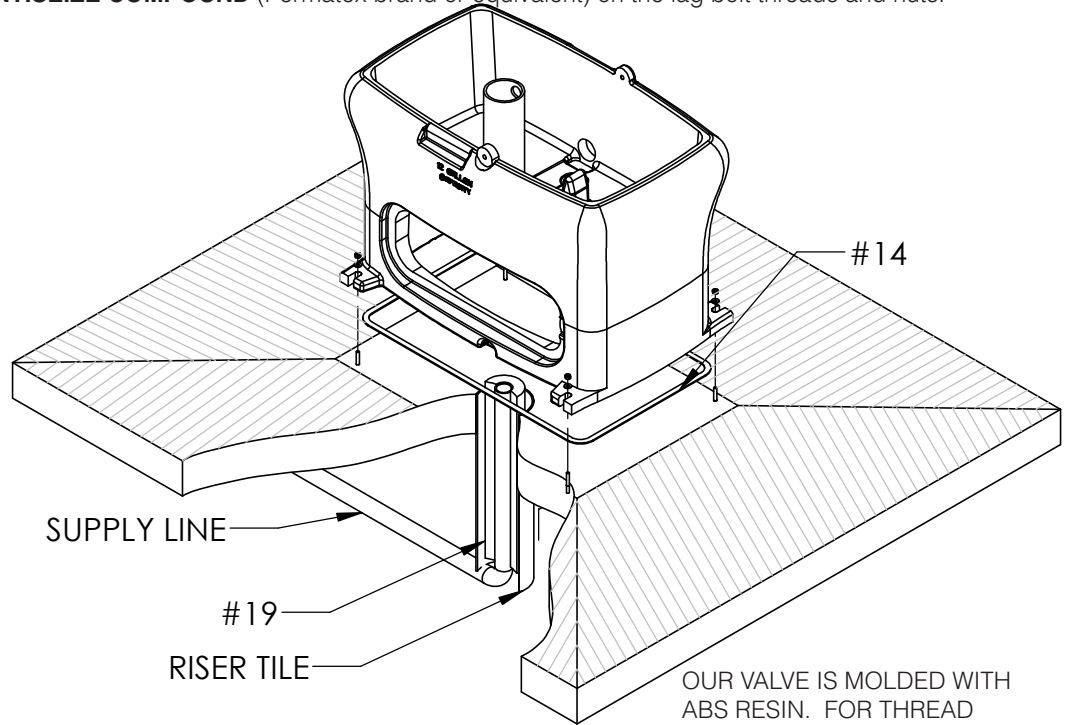

STEP 7:

INSTALL WATER SUPPLY LINE AND VALVE AND PLUGS

1. Apply teflon tape or teflon sealant to threads of **Ref No. 10 Valve**. Place **Ref No. 11 Washer** onto the valve threads. Thread **Ref. No. 15 Valve Supply Line Assembly** down through the riser assembly. Install the valve through the hole in the riser assembly and screw into the elbow of valve supply line assembly. Snug the valve so that the valve arm is in the down position. You can tighten the valve base to the tee with a 1" box end wrench
2. Install **Ref No. 12 Rubber Stopper** in the inside of the vertical sidewall. Push it in from the outside and allow the water to drain onto the ground when cleaning.
3. Apply teflon tape or thread compound to the threads of **Ref. No. 13 Plastic Plug**. Install plastic plug into the 1 1/2 inch threaded hole in the base. The purpose of this hole is to give you an internal drain as an option.

- #15
OP350 - ELBOW
OP214 - WORM GEAR CLAMP (X2)
49-1465-20 - SUPPLY HOSE
OP215 - HOSE BARB

OUR VALVE IS MOLDED WITH ABS RESIN. FOR THREAD SEALING, USE ONLY STANDARD TEFLON TAPE OR PLASTIC COMPATIBLE TEFLON SEALANT. DO NOT USE PIPE THREAD SEALANT (COMMONLY CALLED "PIPE DOPE") OR SEALANT FORMULATED WITH PTFE.

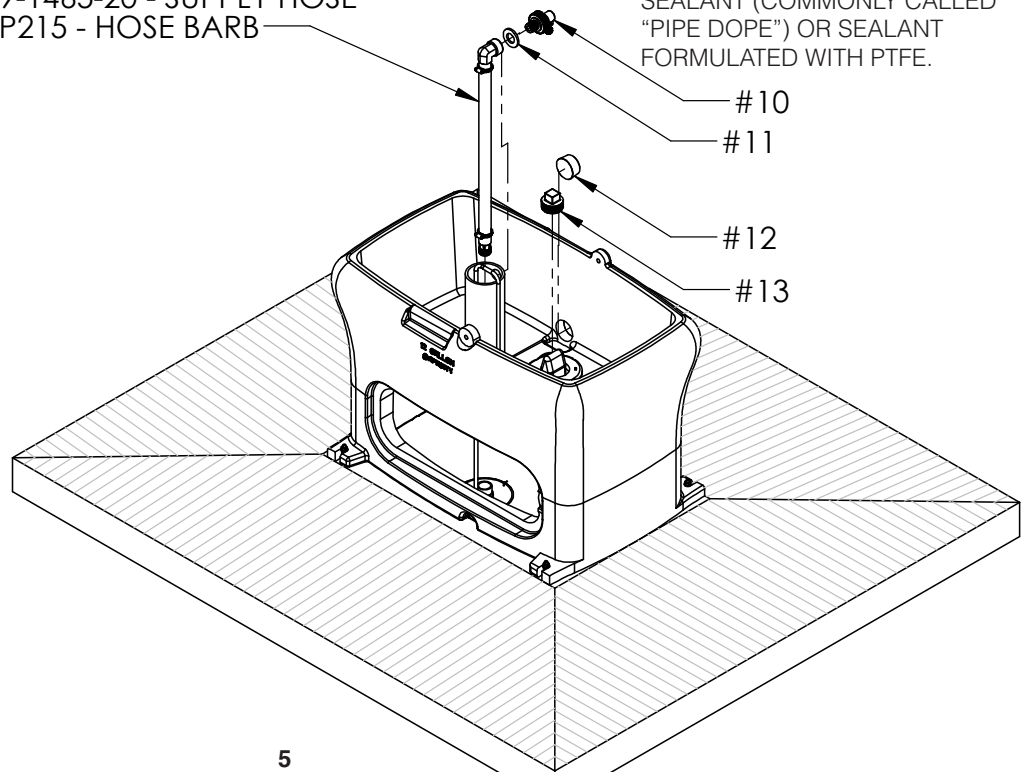

STEP 8: INSTALL FLOAT AND TURN ON WATER

1. Install **Ref. No. 7 Float**. Adjust so that there is no interference with the heater assembly.
2. Turn on water and adjust float so that water fills the reservoir about 1 inch(2.54 cm) from the overflow of the drink opening—or as you desire. Check all connections to make sure there are no leaks.
3. VALVE ADJUSTMENT: All our drinkers are equipped with valves with interchangeable orifices when shipped. This dependable valve has served our customers since 1975. The standard valve for your unit normally operates on a range of 20 to 60 psi. When your drinker is installed on a gravity flow or low pressure system, you may adjust your valve for more water volume by using a larger orifice (VP26). If your drinker is installed on a high pressure water system (over 60 pounds) you may compensate for extra pressure by using a smaller orifice (VP25). For severe high pressure situations, you may need to install a pressure regulator.

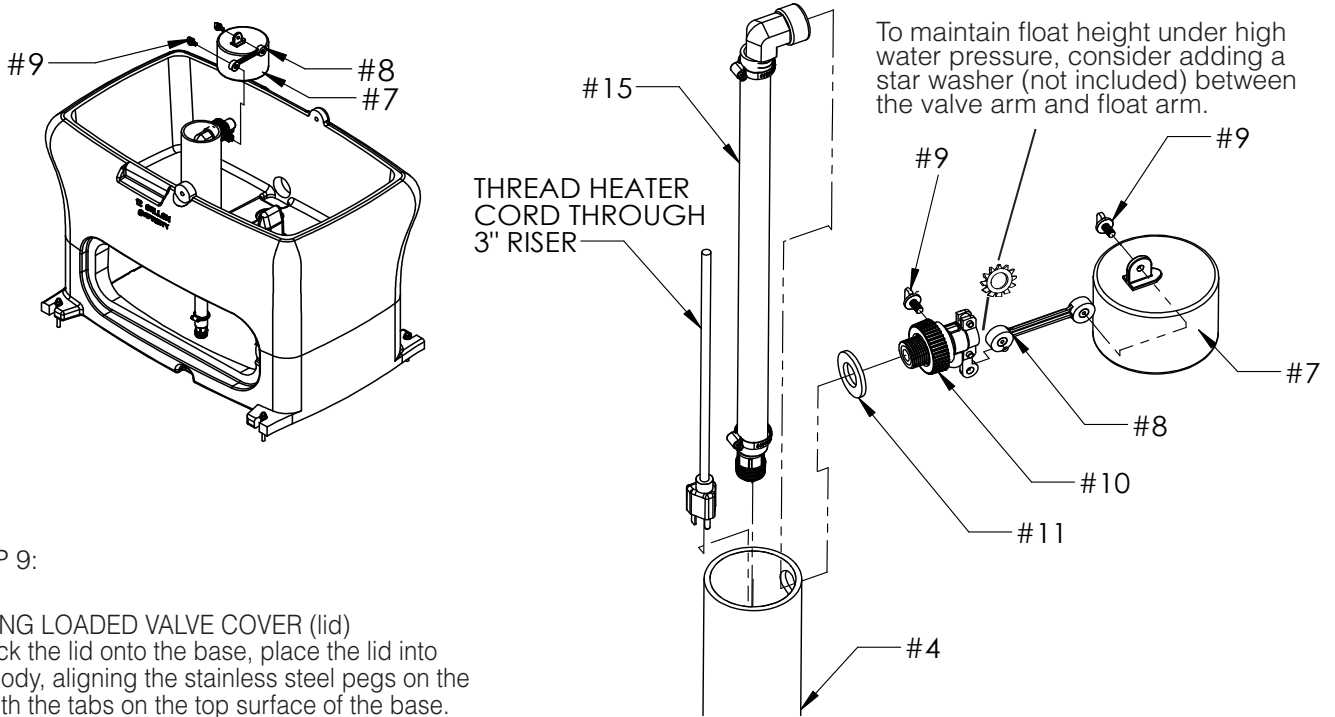

To maintain float height under high water pressure, consider adding a star washer (not included) between the valve arm and float arm.

STEP 9:

SPRING LOADED VALVE COVER (lid)

To lock the lid onto the base, place the lid into the body, aligning the stainless steel pegs on the lid with the tabs on the top surface of the base. With your 2 index fingers, depress the stainless steel pegs and push down on the lid. The pegs will snap into the holes in the tabs.

To remove the lid, take most any instrument such as a screwdriver, end of a pliers handle, even a key. Depress the peg through one tab and pull up on that side of the lid so that the peg is not in the hole. Hold that side of the lid (so that the peg is not in the hole) while depressing the peg on the other side. The valve cover should pop up and off the base.

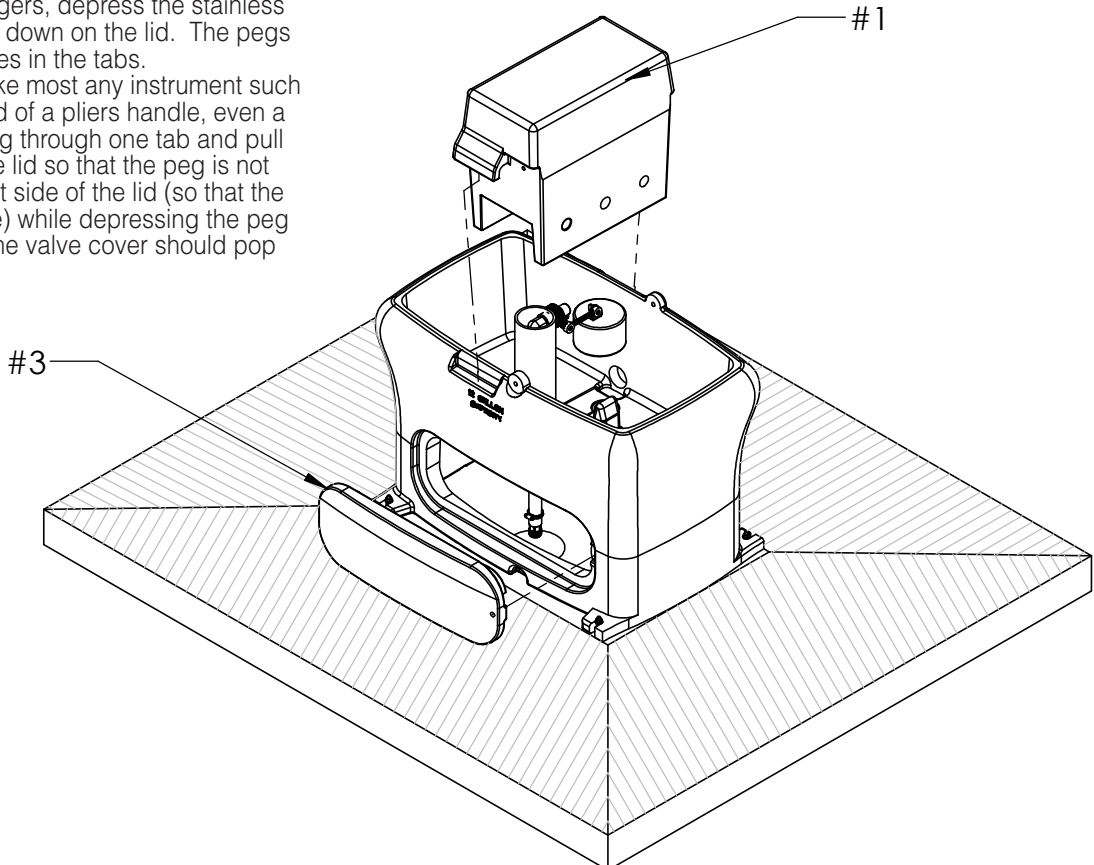

Exhibit D

Valve Cover Parts

Ref. No.	Part No.	Description	Qty.
A	OF572	#14575 SS Cotter Pin .094" Dia c 3/4"	2
B	OF573	#14573 SS Cotter Pin, 4 1/2" L	2
C	OF570	#14574 SS Washer .344" ID x .750" OD	2
D	OF571	#14571 SS Spring .48" OD x 1 3/4" L	2

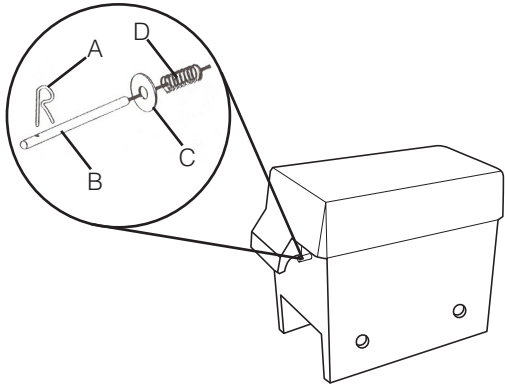
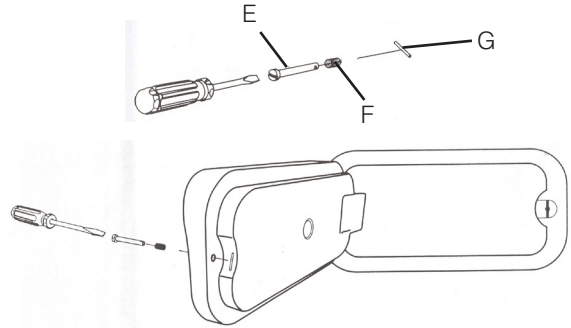

Exhibit E

Access Door Parts

Ref. No.	Part No.	Description	Qty.
E	OF543	Fillister Head Bolt, 1/4"	1
G	VK17	Spring, SS	1
F	OF541	Roll Pin, SS 1/8" x 1"	1



To open access door use a straight blade screwdriver. Turn Fillister Head Bolt one quarter turn and the bolt should pop out.

VP VALVE CAPACITIES
Gallons per Minute
(Liters)

	VP25 3/32" Orifice	VP24 1/8" Orifice	VP26 1/4" Orifice
PS			
20	2.4 (9.1)	3.7 (14.0)	5.0 (18.9)
40	3.70 (14.0)	6.2 (23.5)	8.3 (31.4)
60	4.6 (17.4)	7.7 (29.1)	9.2 (34.8)
80	5.0 (18.9)	7.9 (29.9)	9.7 (36.7)

Ref No.	Part No.	Description	Qty
1	VP29	Valve Arm	1
2	VM106	Link Pin	1
3	VP21	Body	2
4	VP28	Plunger	1
5	VP24	1/8 Orifice	1
6	VP112	O-Ring	1
7	VP13	3/4 NPT Base, Poly	1
8	VP15	Assembly Nut	1

Model VP24 1/8 inch orifice comes standard with Model VP223 valve.

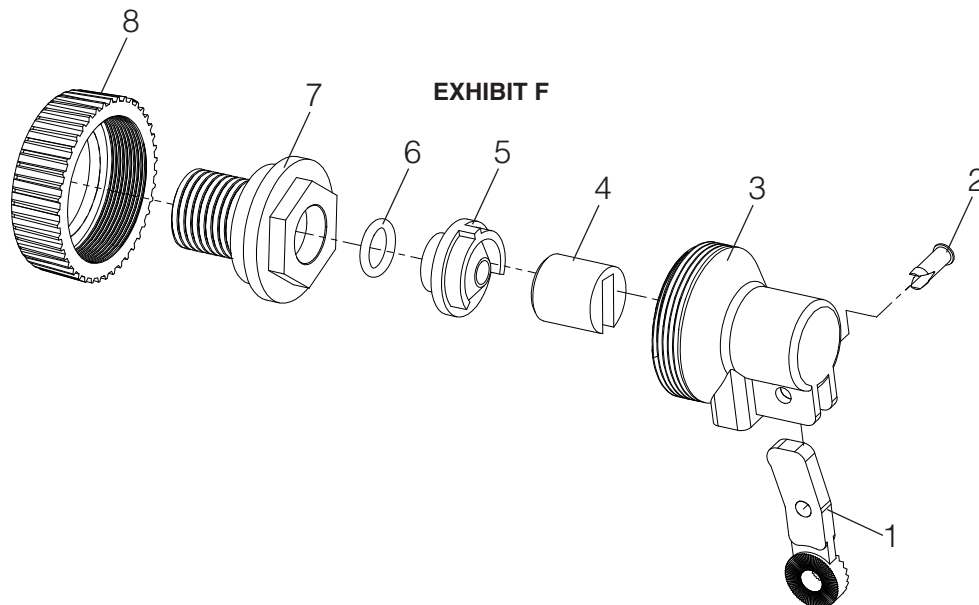

SUGGESTION: Mount an waterproof electrical box on the inside of the drinker lower cavity using 1" wood screws. Mounting on the left side works well for a right handed person & vice versa. This makes it easy to plug in & later remove the heater and the heat tape. **Your heater (de-icer) will have a longer life if you unplug and remove from the water when not being used.** The drinker shall be on a dedicated 15A GFI circuit.

HEAT TAPE SUGGESTIONS: Wind the tape around the valve or hold it there with electrical tape. Then, wind around the water line. You can extend it down into the foam pipe insulation (Ref No. 19) Do not wrap it around the heater electrical supply cord

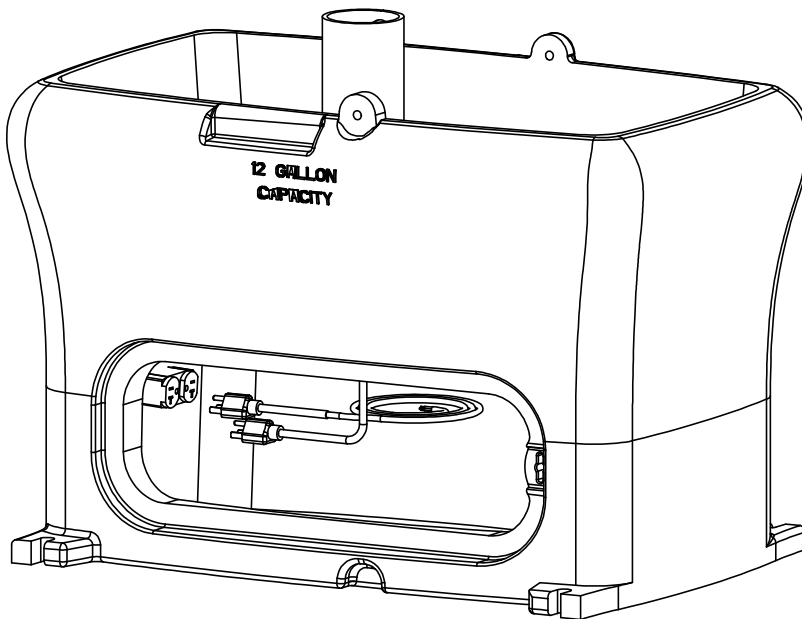

HEATER OPERATION:

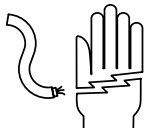



WARNING



DISCONTINUE ELECTRICAL SERVICE TO ELECTRIC SUPPLY LINE BEFORE REMOVING THE HEATER.

Farm Innovators Model C250 Utility De-Icer standard specifications are 250 Watts / 120 VAC / 2.0 AMPS/60 HZ/1 PH. The heat range is about 34° F to 45° F (1°C to 7°C). The de-icer only works when the temperature approaches freezing. It is thermostatically controlled to turn on at freezing and to turn off when the temperature is above freezing.

If unit freezes in the drinker due to the loss of power, allow unit adequate time to melt itself free. Do not chop or cut at unit while plugged in.

Low voltage is a possible cause for failure or poor performance. Measure voltage at receptacle with unit energized. Voltage drop means wattage reduction. Extension cords cause voltage drop and are unsafe.

IMPORTANT! DO NOT ALLOW DEPOSITS TO BUILD UP ON THE HEATING ELEMENT. This can cause "hot spots" which is a primary reason of failure and voids the warranty. White vinegar or "Lime Away" can be used to clean the tubular element. **WE RECOMMEND REMOVING THE DE-ICER WHEN NOT NEEDED.**

When taking unit out of service, disconnect power supply cord, remove unit from tank, clean element (see above), store indoors.

ALSO, PLEASE NOTE:

1. Do not energize the heater until the drinker is filled with water.
2. Do not operate the unit out of water (except to test - See No. 3 below.)
3. Here's how you can check to see if your heater is working --
 - a) Set unit in freezer for one hour or outside for one hour if temperature is below 35 degrees F (1°C).
 - b) Connect heater to an electrical source. Hold the heater by the cord set. Within seconds, the element should begin to heat. Listen for the thermostat to "click" off. Disconnect the unit. The unit is working properly.

LIMITED WARRANTY

Our part no. OP284P C250 Utility Deicer (heater) and our DURAPRIDE Valve (including float arm, float and adjust screw) carry an 18 month limited warranty. All other components of Hawkeye Steel Products, Inc. Performance One E-Drinks are covered by a five year limited warranty. After the five year warranty period, all components, except valve and heater parts, are covered by an additional 6 year pro-rated warranty. Both warranty periods are from the date of purchase. Each drinker must be registered with Hawkeye Steel Products, Inc. on the card which accompanies each drinker. Warranted components should be returned to your dealer for shipment to our factory -- Highway 16 West, P.O. Box 2000, Houghton, IA 52631 USA, Fax 319-469-4402; 800-553-1791. Warranty is limited to the repair or replacement of components. The warranty does not cover removal or reinstallation; cost to transport and retrieve components for repair; damage or loss occurring during transport; damage due to foundation design; damage caused by natural or environmental conditions (acts of God); costs associated with loss of time and/or inconvenience or any other consequential damages; injury; lack of animal performance; loss of profit; life of property; malfunction resulting from misuse, improper installation, lack of maintenance (such as not periodically removing deposits on the deicer), unauthorized alteration, or negligence. All provisions stated on the back of Hawkeye Steel Products, Inc.'s invoice apply and Hawkeye Steel Products, Inc. assumes no consequential damages.